



BEDFORD PUMPS LTD.

+44 (0)1234 852071

sales@bedfordpumps.co.uk

www.bedfordpumps.com



Vertical Turbine Pumps

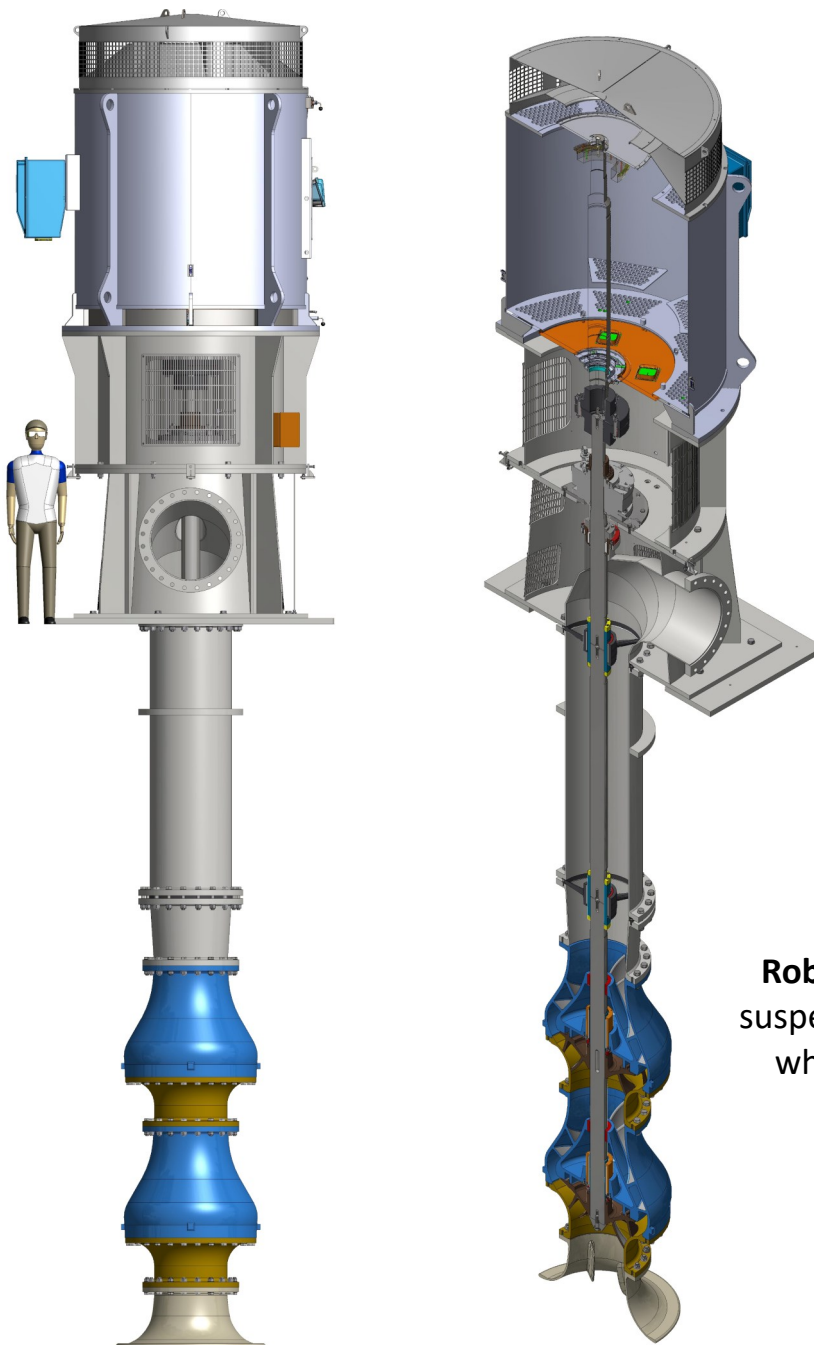

**Robust, energy efficient
suspended bowl pumps for
when it really matters.**

DA & DB RANGE

Bedford Pumps Ltd

Bedford Pumps Ltd are world leaders in the design and manufacture of high capacity vertical suspended bowl pumps. Single and multistage units with radial, mixed or axial flow hydraulics are available in a wide range of material options suitable for raw, treated and salt water applications. ATEX compliant options are also available for hazardous area applications, such as storm water pumping.

Quality Assurance

Bedford Pumps operate a quality system approved to ISO 9001:2015 for the design, development and manufacture of rotodynamic pumps and the design, development, procurement, installation and commissioning of pumping systems for the water and sewerage industries. This is in addition to the company's project management of pumping systems projects for the water and sewerage industries.



Pre-Engineered Hydraulics Range (head per stage)

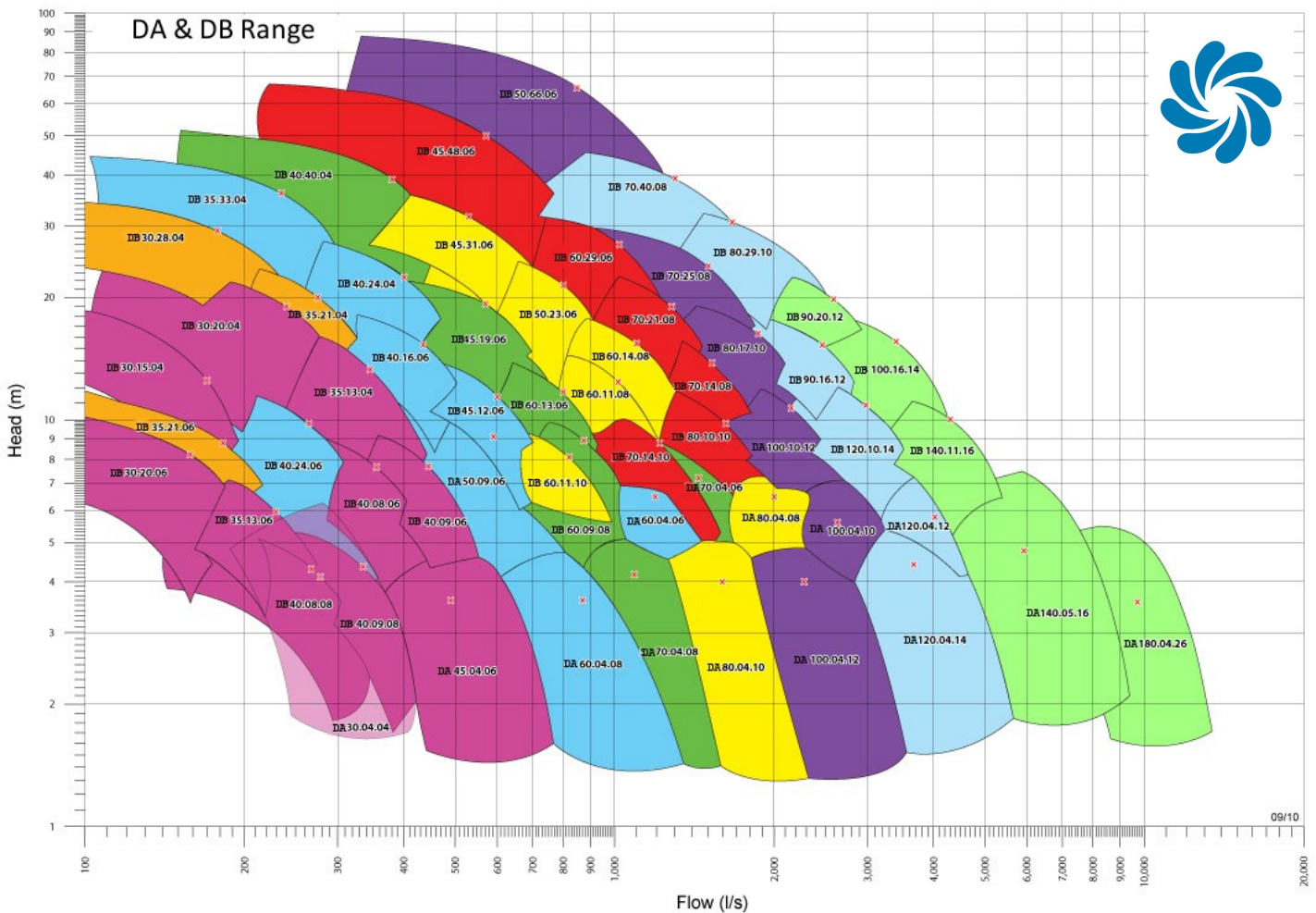

Chart shows the most efficient pump for any given flow rate. Depending on other factors (cost and system curve etc.) this may or may not be the best selection for a given duty.

Bedford Pumps Ltd, Brooklands, Woburn Road Industrial Estate, Kempston, Bedfordshire, MK42 7UH Tel: (01234) 852071 Fax: (01234) 855620 sales@bedfordpumps.co.uk www.bedfordpumps.co.uk

★ Large engineered to order pumps are available outside of this envelope.

Features and Capacities

- Above and below floor discharge arrangements
- Closed and semi open impeller options
- Wide range of material options
- Branch sizes up to 2200mm
- Flow rates up to 15,000 litres per second
- Heads up to 250m



Typical Applications

- Water abstraction and supply
- Flood alleviation
- Surface and Storm Water pumping
- Dock dewatering and impounding
- Cooling Water circulation
- Irrigation



Pump Construction

Materials of Construction

All castable corrosion and erosion resistance material options are available from grey and ductile cast irons to austenitic and duplex stainless steels.

Thrust Bearing

Heavy duty air cooled thrust bearing options are available.

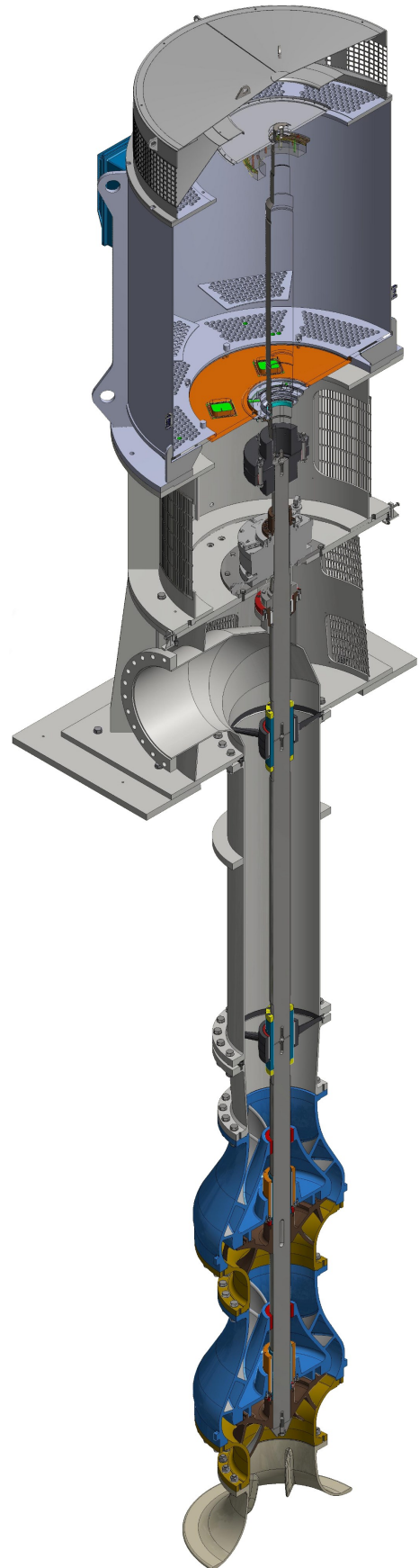
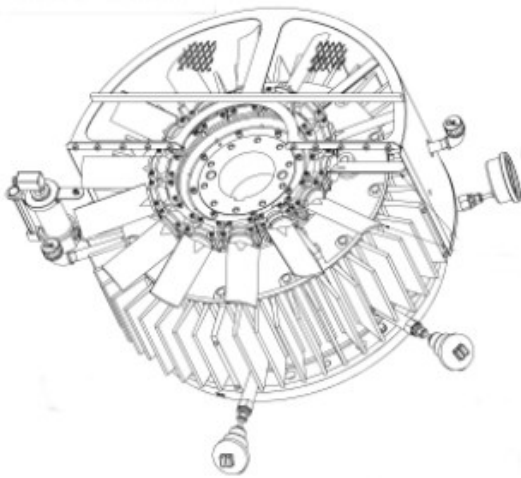

Controlled Leakage Device

Controlled leakage devices as an alternative to packed glands or mechanical seals are a maintenance free option for low head applications.

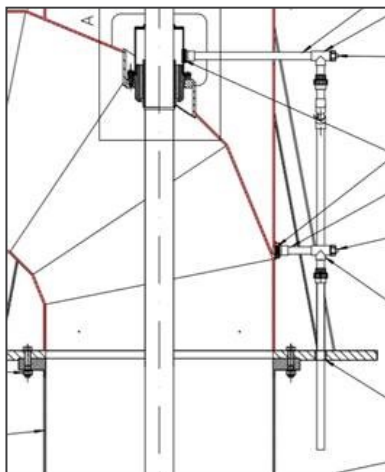

Pump Construction

Bowl Assemblies

The bowl assemblies incorporate a range of integral diffuser options, providing high hydraulic efficiency and or solids passing capabilities.

Impellers

A comprehensive range of radial, mixed or axial flow impeller options are available to ensure the optimum performance and highest operating efficiencies can be offered over a wide range of heads and flows.

Fully shrouded and semi-open impeller options are available to suit the application in a wide range of material options, from cast irons to bronzes and high alloy stainless steels.

Suction Bellmouth and Draft Tube Options

Ensuring the correct inlet conditions is a critical factor for high capacity pumps, hence a range of low loss bellmouth and draft tube design are available incorporating flow conditioning features to optimise inlet velocity profiles.

Bearings

A comprehensive range of thrust bearing options are available including air and water-cooled antifriction or tilting pad arrangements to ensure long bearing life regardless of dynamic loads. Water jacket or coil cooled options are available.

Similarly, a wide range of radial transmission bearing options are available, either lubricated by the pump fluid or housed within a separate enclosing tube and lubricated by external water sources or lubricants.

Shafts

Shaft arrangements are engineered to suit the application, thus long length single shafts without intermediate support bearings can often be engineered for handling solids laden fluids. All our shaft systems are designed as "Stiff Shaft" construction, operating well below the shafts first critical speed.

Shaft Seals

Soft packed glands, controlled leakage devices and a range of split, single or double mechanical seal arrangements, with supporting seal plans, are available to ensure reliable shaft sealing on all applications.

Typical Arrangements

The extremely versatile design of these pumps allows a wide variety of installation configurations to be used without impairing performance.

Above or Below Floor Discharge

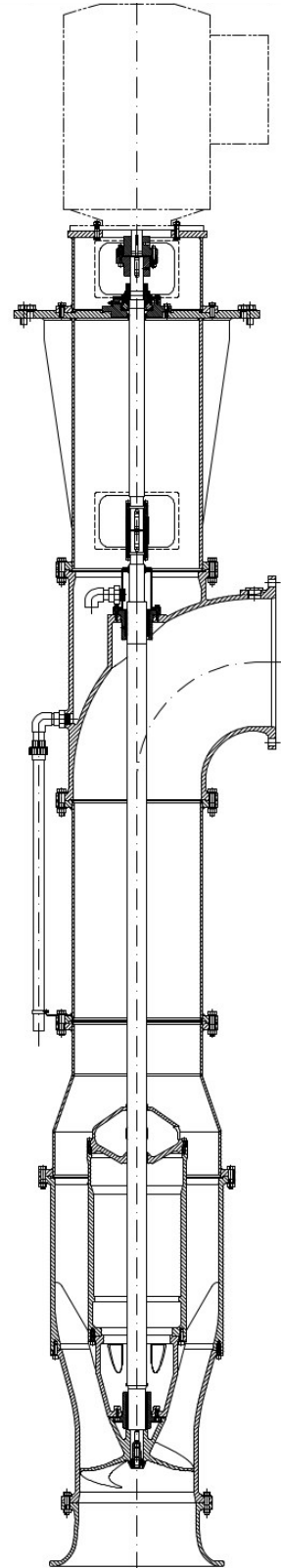
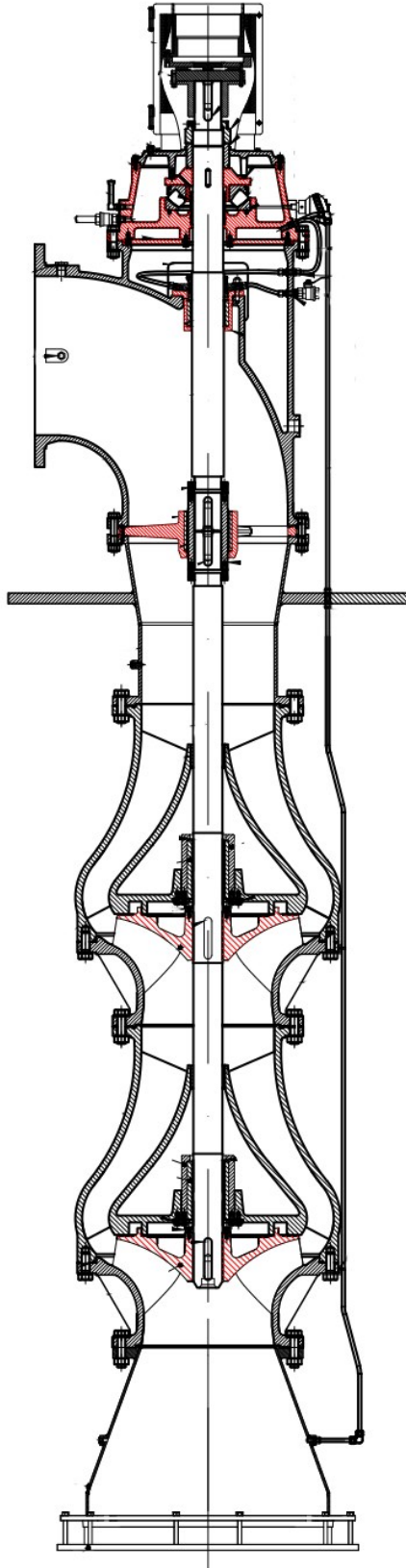

Project Management & Installation

In addition to innovative design, Bedford Pumps also has the Project Management capability to offer full Mechanical and Electrical packages.

This offers the client a one stop solution for the design, manufacture, testing, installation and commissioning of pumping station plant, whether for existing stations requiring up-grading, or for new projects.

Typical plant included are Motor Control Centres, Telemetry and other Instrumentation, Site Cabling, Transformers, Generating Sets, Pipework, Valves, Steelwork, Screens and Cranes.



Our staff are fully conversant with the latest HSE site regulations and are trained in confined space operation, mechanical handling, method statements and risk assessments, ensuring first class professional installation at all times.

Prior to operating a pump for the first time, checks must be carried out to ensure that the mechanical and electrical installation is complete and satisfactory in all respects. These include electrical, mechanical, pre-start checks and operation checks.

Service



Bedford Pumps offer a range of aftersales service options for installed equipment, including condition monitoring and both on and off-site servicing and repairs.





Bedford Pumps Ltd. Brooklands, Woburn Road Ind Estate, Kempston, Bedford, MK42 7UH, UK.
Tel: +44 (0)1234 852071 Email: sales@bedfordpumps.co.uk Website: www.bedfordpumps.com

